



NATIONAL INSTITUTE OF TECHNOLOGY SIKKIM

Ravangla Campus

Barfung Block, Ravangla Sub Division, South Sikkim-737139

Tender No: NITS/S&P/FURNITURE/18-19/75

Date: June 15th, 2018

Notice Inviting Tender

National Institute of Technology Sikkim invites tenders/bids under two bid system (Technical Bid & Financial Bid both in separate sealed envelopes) in sealed envelope for fabrication & supply of student cots as per specification, terms and conditions given in this tender to be fabricated at NIT Sikkim, Ravangla, South Sikkim 737139. The tender documents can be downloaded free of cost from the website www.nitsikkim.ac.in or from the Central Public Procurement Portal.

Schedule of Requirements

| Name of Item | Quantity | Delivery period |
|-----------------------------------|----------|-----------------|
| Stainless Steel Double Decker Cot | 100 | 30 Days |

| Details | Information |
|---|--|
| Bidding System | Two bid system: Technical Bid & Financial Bid (separate sealed) |
| Tender Floating Date | June 15 th 2018 |
| Tender Closing Date & Time | June 26 th , 2018 (11:00 AM) |
| Technical Bid Opening Date & Time | June 26 th , 2018 (12:00 Noon) |
| Financial Bid Opening Date & Time (Tentative) | June 26 th , 2018 (04:30 PM); Shall be announced at the time of technical bid opening. |
| EMD | Rs 50,000/- (Rupees Fifty Thousand Only) By Demand Drafts in favour of "The Director, NIT SIKKIM" payable at State Bank of India, Ravangla Branch (IFSC SBIN0007218). |
| Address for communication | Registrar, NIT Sikkim Barfung Block, South Sikkim, Sikkim PIN 737 139, INDIA |
| For any Clarification | <i>e-mail:- purchaseoffice@nitsikkim.ac.in</i> |
| Website | <i>www.nitsikkim.ac.in</i> |

Registrar

GENERAL TERMS AND CONDITIONS

1. In this tender document the BUYER means National Institute of Technology Sikkim (NIT Sikkim) and SELLER means the successful bidder awarded the purchase/work order. The Institute means NIT Sikkim. The word “tender” and “bid” is used interchangeably having same meaning. Here, the contract means the Purchase order for the goods given in the scope of the work.
2. **Scope of Work:**
Experienced fabricators/manufacturers, of stainless steel furniture may bid for the onsite manufacturing/fabrication of Stainless Steel Double Decker Cot for student hostels at NIT Sikkim. The trade license submitted by the bidder must clearly mention the trade in which the bidder operates. Here metal/steel furniture is necessary.
3. **Format for submission of bid:**
The bid shall be submitted only in the *forms and formats* attached with this bid document and every page of the bid document should be signed and stamped by authorized person. The bid should be forwarded by the bidders under their original memo/letter head inter alia furnishing all the required details like GST number, PAN NO., Bank details etc. and complete contact details (Postal address, email, fax, contact numbers) of their office. All bidding documents and rate quotations must be in English. One signed copy of the tender document, with bidding firm seal, agreeing to the terms & conditions and declaration etc. must also form part of the submitted bid.
4. **Two Bid system:**
The bidding process shall consist of TWO bid system. The bid must be submitted in two parts comprising: **Part-I: Technical Bid [Annexure-A] & Part-II: Financial Bid (i.e. price bid) [Annexure-B]**.
The Part-I (Technical bid) should contain the EMD, compliance/non-compliance of detailed technical specifications as per the Bid/TENDER document along with other desired information/certificate, etc. The Part-II (Financial Bid) shall only contain the price offered in the Bid format provided with document along with other desired information/certificate, etc, if any.
Both the Bids (parts) should be properly placed in two separate sealed envelopes and marked accordingly (**must super-scribed TECHNICAL BID or FINANCIAL BID on the top of each respective envelope**) for their proper identification. These should again be sealed in a third bigger envelope super-scribing, **“Bid for Procurement of Stainless Steel Double Decker Cot”**.
The Part-I (Technical bid) will be opened on the date of tender opening and the Part-II (Financial Bid) after evaluation of Part-I. The Part-II (Financial Bid) of only technically qualified bidders shall be opened, as decided by the Technical Evaluation Committee. The decision of the Technical Evaluation Committee shall be final and binding on all the bidders.

[Seal and Signature of the firm]

5. Enclosures:

The bidder must attach the suitable supporting documents. The Technical and Financial/Commercial bids will be submitted in the specific formats enclosed with this tender document in separate sealed envelopes. All the enclosures attached with the bid shall also be signed and stamped. Please ensure following:

(a) **Technical bid** must comprise of following:

- (i) A clause by clause compliance on Terms and Conditions of the Contract and the Technical Specifications, drawings, etc.
- (ii) Duly filled, signed and stamped **technical bid** on the letter head [Annexure-A].
- (iii) Duly filled, signed and stamped undertaking on the letter head [Annexure-C].
- (iv) **All the certificates and declarations required under the Specific Conditions of this TENDER/BID document.**
- (v) The bidder may submit/supply records and satisfactory installation certificate of completing similar turnkey work, if any.
- (vi) EMD in the form of Demand Draft must be enclosed with the Technical Bid.
- (vii) **Trade license**/Certificate of registration (As applicable) of the agency with the government in the required business/field will be enclosed with technical offer.
- (viii) Brief description about the company including projects executed with Government organizations/Institutions, showing size, cost and completion details of each project.
- (ix) The **GST registration** number and photocopy of certificate.
- (x) **The PAN number** of proprietor/firm/company with photocopy of the PAN card.
- (xi) A declaration of the brand of components to be used in the fabrication and its certification must be enclosed in the bid documents.
- (xii) The enclosed formats in original should be used for the Bids. All sheets submitted must be signed by the authorized signatory of the company and duly affixed with firm's stamp. Additional sheets, duly authenticated may be attached to elucidate specific issue, if any.

Noncompliance of any of the above may result in rejection of the bid summarily and no query in this regard shall be entertained.

(b) **Financial Bid/Price Bid:**

Financial bid will comprise of duly filled, signed and stamped Financial Bid in the format given at **Annexure-B** - Financial Bid/Price Bid only and must be placed in separate envelope duly sealed and signed. This envelope must be super-scribed with "**Financial Bid for Procurement of Stainless Steel Double Decker Cots**".

6. Bid Security:

The Bid Security (i.e. Earnest Money Deposit, EMD) in the form of Demand draft from any scheduled bank drawn in favor of "Director, NIT SIKKIM" payable at RAVANGLA, South Sikkim-737139 must accompany with **Technical Bid**. **No interest shall be paid on the submitted EMD**. Offer without EMD will be rejected

[Seal and Signature of the firm]

summarily except in case of exempted bidders holding valid MSME/NSIC license exempting such bidders from furnishing of EMD.

The Bid Security of unsuccessful bidders shall be refunded after finalization of bid/award of contract to successful bidder. EMD of the unsuccessful Bidders will be returned to them at the earliest after expiry of the final bid validity and latest on or before the 30th day after the award of the contract. The Bid Security of the successful Bidder would be returned after the receipt of Performance Security as called for in the contract/adjusted towards performance security. No interest shall be payable to any bidder on the EMD with the Institute. The EMD of the technically disqualified bidders may be returned in original (i.e. the Demand Draft submitted along with bid).

The Bid Security shall be forfeited, (i) if a Bidder withdraws its bid during the period of bid validity; or (ii) if a Bidder makes any statement or submits any information which turns out to be false, incorrect and / or misleading at any time and / or conceals or suppresses material information: or (iii) in case of successful Bidder, if the Bidder fails to sign the contract/agreement or furnish performance guarantee within the specified time period. The decision of the institute authorities shall be final and binding on the bidder(s).

7. Amendment in Bid/Tender Document.

At any time up to the last date of receipt of Bids, the Institute may, for any reason, whether at its own initiative or in response to a clarification requested by a Bidder, modify the Bid/tender document by an amendment. The amendment will be notified in writing through Institute website or email (if provided) to all the prospective Bidders, the same shall be binding on all the prospective bidders.

The Institute may, at its discretion, extend the last date for the receipt of Bids/cancel the Bidding process. It shall be the responsibility of the interested bidder(s) to regularly visit the website for any amendment/ information.

8. Bid Disqualification:

The proposal is liable to be disqualified in the following cases:

- (a) Proposal not submitted in accordance with instructions provided in this document.
- (b) Proposal is received in incomplete form.
- (c) Proposal is received after due date and time.
- (d) Proposal is not accompanied by all requisite supporting documents.
- (e) The Financial Bid/Price Bid is placed in the same envelope as the Technical Bid.
- (f) If bid is not accomplished with EMD as per the clause given in this bid document.
- (g) Canvassing by the Bidder in any form, unsolicited letter and post-tender correction will invoke summarily rejection of the bid and may result in forfeiture of EMD.
- (h) Conditional tenders/Bids will be summarily rejected.
- (i) Bidder fails to deposit the Bid Security/Performance security or fails to enter into a contract within specified date of notice of award of contract or within such extended period, as may be specified by the Institute.

[Seal and Signature of the firm]

9. Queries and Clarification:

The queries and clarification in this Bid/Tender must be addressed to “Registrar” and the same must be sent through conventional mail as well as email/Fax in the format below:

| S. No. | Clause no. (as per the Bid/TENDER) | Your understanding / interpretation | Clarification sought from Institute |
|--------|------------------------------------|-------------------------------------|-------------------------------------|
| | | | |

10. Clarification regarding contents of the Bids:

During evaluation and comparison of bids, the Buyer (NIT Sikkim) may, at its discretion, ask the bidder for clarification of his bid. The request for clarification will be given in writing (post/fax/email) and no change in prices or substance of the bid will be sought, offered or permitted. The clarification must be provided within the time stipulated by the Institute else the bid submitted may be rejected. No post-bid clarification on the initiative/request of the bidder will be entertained.

11. Withdrawal of Bid Submitted:

Bidders unwilling to participate in the bidding process after submitting the bid must ensure that intimation to this effect must reached the Registrar, NIT Sikkim before the due date and time of the opening of the Bids, failing which the defaulting Bidder may be delisted and will result in forfeiture of EMD.

12. Right to Accept/ Reject Bids:

The Institute reserves the right not to accept any bid and to annul the tender/bid process and reject all bids at any stage, without thereby incurring any liability or assigning any reason to the affected Bidders or any obligation to inform the affected Bidders on the grounds for such action.

13. Confidentiality:

The Bidder and their personnel shall not, either during the term or after expiration of this work order, disclose any proprietary or confidential information relating to the services, agreement or the Institutes business or operations without the prior written consent from the Institute.

14. Force Majeure:

During the pendency of the service agreement if the performance in whole or part thereof, by either party is prevented/delayed by causes arising due to any war, hostilities, civil commotion, act of public enemy, sabotage, fire, floods, explosion, epidemics, non-availability of raw material and other consumables, or any other causes including breakdown of equipment beyond their reasonable control. Neither of the two parties shall be made liable for loss or damage due to delay or failure to perform the contract during the pendency of forced conditions provided that the happenings are notified in writing within 7days from the date of occurrence. The work shall be resumed under the contract as soon as possible after the restoration of normalcy. The Institute reserves the right to grant time period extension on the request of bidder or otherwise.

[Seal and Signature of the firm]

15. Termination of Work Order:

The Institute may, without prejudice to any other remedy for breach of agreement, may terminate the purchase order/ work order/contract/agreement in whole or in part, by written notice of default sent to the Bidder, and the performance guarantee shall stand forfeited if:

- (a) The Bidder fails to deliver any or all of the obligations within the time period(s) specified in the purchase order/ work order/contract/agreement, or any extension thereof granted by the Institute.
- (b) The Bidder fails to perform any other obligation(s) under the work order/agreement and fails to rectify it within the notice period for the rectification of the same.
- (c) Information submitted in technical proposal is found to be misrepresented, incorrect or false, accidentally, unwittingly or otherwise, at any time during the processing of the contract (no matter at what stage) or during the tenure of the contract including the extension period if any.
- (d) The loss incurred due to termination of the work and addition cost incurred in completion of the work by any other firm, selected by the institute shall be recovered from the defaulted firm/party.

16. Termination for Insolvency:

The Institute may at any time terminate the work order by giving written notice to the Bidder without compensation, if the Bidder becomes bankrupt/insolvent, provided that such termination shall not prejudice or affect any right of action or remedy which has accrued thereafter to the Institute.

Note: Termination shall be based on the advice of Technical Committee constituted by the Institute.

17. Periodic monitoring and review:

The work and progress of the work shall be periodically monitored and reviewed by a committee constituted by the Institute for this purpose.

18. Suspension:

The Institute may by a written notice of suspension to the Bidder, suspend all payments to the Bidder under the work order, If the Bidder fails to perform any of its obligations under this work order/contract/agreement, (including the services).

19. Bid Evaluation Criteria:

The broad guidelines for evaluation of Bids will be as follows:-

- (a) Only those Bids will be evaluated which are found to be fulfilling all the eligibility and qualifying requirements of the Bid/TENDER document, both technically and financially/commercially.
- (b) In respect of Two-Bid system, the technical Bids Submitted by the Bidders will be evaluated by the Buyer Technical evaluation Committee (TEC) with reference to the technical specifications of the goods as mentioned in the BID/TENDER. The compliance of Technical Bids would be determined on the basis of the parameters and specifications specified in the BID/TENDER

[Seal and Signature of the firm]

document. The Financial/Price Bids of only those Bidders will be opened whose Technical Bids shall qualify the technical evaluation.

- (d) The Bidders are required to spell out the rates of GST, etc. in unambiguous terms; otherwise their offers will be loaded with the maximum rates of duties and taxes for the purpose of comparison of prices.
 - (e) If there is a discrepancy between the unit price and the total price that is determined by multiplying the unit price and quantity, the unit price will prevail and the total price will be corrected by the Institute Committee. If there is a discrepancy between words and figures, the amount in words will prevail for calculation of price and comparison of bids.
 - (h) NIT Sikkim reserves the right to modify in exceptional case any of the stipulated terms and conditions on merit / genuine and justifying grounds if it is in the larger interest of the Institute. The final acceptance of the tenders rests entirely with the NIT Sikkim who does not bind himself to accept the lowest tender. The lowest price may not be the sole criteria for deciding the successful bidder, the institute is free to take other factors in deciding the successful bidder for award of purchase order/ work order/contract/agreement in the interest of the Institute and its stakeholders. The Institute committee reserves all rights in this regard and no query or complaints in this regard shall be entertained. The selection will be made purely on the basis of committee's recommendation, genuineness of the firm and based on the technical specification of various products as per printed catalogues & also on the basis of experience, performance, promptness of delivery and requirement of the institute.
20. **Firms/Bidders shall be required to accept all the Terms and Conditions mentioned in this BID/TENDER or modified/amended made and shall be the part of the purchase order/ work order/contract/agreement.**
21. **Placement of Order:**
The Purchase/Work Order will be placed on successful completion of the process to the successful bidder. Once supply order is placed, it will be the firm/vendor's responsibility to supply the goods and complete the work awarded to the satisfaction of the Institute. It shall be the sole responsibility of the firm/vendor (Successful Bidder) to make the project functional in all respect. Any additional cost incurred on account of this, for which the firm/vendor has not bid/quoted at the time of submission of the bid offer, will be borne by the firm/vendor.
22. **Arbitration:**
All disputes or differences arising out of or in connection with the purchase order/ work order/contract/agreement shall be settled by bilateral discussions. Any dispute, disagreement or question arising out of or relating to the Contract or relating to the performance, which cannot be settled amicably, may be resolved through arbitration. The standard clause of arbitration will be as per the Institute norms/decision. All disputes, differences, claims and demands arising under or pursuant to or touching the agreement shall be referred to the sole arbitrator to be appointed by the Institute. The award of the sole arbitrator shall be final and binding on both the parties under the

[Seal and Signature of the firm]

provisions of the Arbitration and Conciliation Act, 1996 or by statutory modification/re-enactment thereof for the time being in force. Such arbitration will be held at NIT SIKKIM. It is clarified that Civil court shall have no jurisdiction to entertain any such disputes.

23. **Jurisdiction of Courts:**

In all matters and disputes arising here under, the appropriate Courts at Sikkim only shall have jurisdiction to entertain and try them only after the failure of arbitration process, if any.

SPECIFIC TERMS AND CONDITIONS

1. Experienced fabricators/manufacturers of Metal/steel furniture must have trade license in steel/metal furniture trade.
2. The place of fabrication shall be NIT Sikkim campus Ravangla, South Sikkim. The seller must ensure start of fabrication work at NIT Sikkim Ravangla campus within 7 days of award of contract.
3. Components must be ISI certified and the components used in the making of the item must be clearly mentioned. A declaration of the brand of components to be used in the fabrication and its certification must be enclosed in the bid documents. The declaration stating willingness to fabricate goods as per specification must be attached.
4. Bidder should have valid GST registration for the financial year 2018-19. Only invoices with serial numbers and printed with GSTIN number shall be accepted.
5. Bid or order may be cancelled or delivered furniture may be not be accepted fully or partially at any time if it is found that stainless steel double decker cot differs or deviates from NIT Sikkim's mentioned and accepted specification in the bid. Any action under this clause shall make the EMD/security deposit liable to be forfeited.
6. Packing, forwarding, insurance (if any), transportation charges should be inclusive in the price. For any damage/loss during transit, supplier will be solely responsible and damaged/lost furniture must be replaced by supplier at their own cost.
7. **Validity:** Bids shall remain valid for 180 days from date of the Tender closing Date.
8. All the terms and conditions mentioned herein must be strictly adhered to by all the vendors. Conditional tenders shall not be accepted on any ground and shall be rejected straightway. Conditions mentioned in the tender bids submitted by vendors will not be binding on NIT Sikkim
9. **Delivery Period:** Delivery period for the cots shall be 30 days from date of issue of Purchase order. The institute reserves the right to extend the delivery time on the request with valid reason. Liquidity damage will be levied in case of failure to abide by the delivery period.
10. Responsibility of ensuring quality with specification lies to the supplier. The supplying firm must ensure approval of the sample cot by the committee before delivery. Deviation of technical specification from the approved sample may lead to rejection of delivery or cancellation of order along with forfeiture of EMD. However, in case of minor change in design may be asked by the institute based on the sample and successful bidder is bound to comply with the same.

[Seal and Signature of the firm]

11. If supplier fails to deliver the cots within the delivery period, NIT Sikkim may cancel full order or parts of the order and EMD value may not be returned to the bidder. NIT Sikkim also reserves the right to place the order for the cots to other bidder or supplier in case of failure of the successful bidder. The EMD shall be forfeited in case the supplier withdraws his tender offer during the validity period of the bid.
12. **Warranty/Guarantee support:** six months onsite comprehensive warranty from the date of successful completion of work should be provided by the bidder. Certificate mentioning acceptance of this clause should be enclosed with the bid.
13. **Extra Features:** If the bidder provides any other extra features on the material/specification which are not mentioned in the tender product specifications, then that shall be highlighted in clear terms, with documentary evidence/literature.
14. Bidder may choose authorized representative with proper authorization letter for attending tender document opening.
15. A bid submitted with false information will not only be rejected but also the bidder will be debarred from participation in future tendering process of NIT Sikkim.
16. In case of any dispute, the decision of the Institute Authority shall be final and binding on the bidders.
17. Credential of supply of similar fabricated furniture to central Govt. / autonomous educational Institute may be attached.
18. The authority is not bound to accept the lowest quoted rate if the bidder does not fulfill all requisites as considered necessary in any case the quality of product will not be compromised.
19. Any defective material pointed out by authorized representative of the Institution the same shall be taken back by the suppliers for replacement at their own cost.
20. The bidder must enclose a valid trade license, GST registration certificate, PAN, or any other certificate evidencing quality, or statutory compliance along with the bid documents duly certified to be true copies.
21. NIT Sikkim may waive any minor informality or non-conformity or irregularity in a bid, which does not constitute a material deviation, provided such a waiver, does not prejudice or affect the relative ranking of any bidder.
22. The furniture to be supplied under this contract shall conform to the standards mentioned in the technical specifications. And when no applicable standard is mentioned, to the authoritative standard appropriate to the goods' country of origin and such standards shall be the latest issued by the concerned institution / Organization.
23. NIT Sikkim reserves right to award the order to one or more bidder.
24. Supply of the stainless steel cot shall be to the satisfaction in all terms of NIT Sikkim, else no payment will be made. The decision of competent authority of NIT Sikkim shall be final and binding on firms / Suppliers. NIT may ask for proof of bills or other relevant document for purchase of the material as per desired standard specification i.e. Ply, laminated sheet, square pipes, angles with brands at any time.

[Seal and Signature of the firm]

25. Performance Security:

Within 07 days (seven) of the receipt of purchase order/ work order/contract/ agreement, the successful Bidder shall furnish a Performance Guarantee of an **amount equivalent to 5% of the order value**. Failure of the successful Bidder to comply with this requirement can constitute sufficient ground for the annulment of the award and forfeiture of the EMD in which event the Institute may make the award to the next lowest evaluated Bidder or call for new bids. Performance Guarantee submitted shall be from a Scheduled Commercial Bank only. Performances guarantee in the form of Demand Draft, Fixed deposit receipt /Bank Guarantee in the standard format from a scheduled commercial bank shall only be acceptable. Performance Bank Guarantee should be valid upto 60 days beyond the date of warranty/last date of contract period.

26. Liquidated Damages (LD) and Penalty Clause for Delay:

In the event of the Seller's failure to submit the Bonds, Guarantees and Documents, supply the stores/goods and conduct trials, installation of equipment, training, etc. as specified in this contract, the Buyer may, at his discretion, withhold any payment until the completion of the required work(s) as per the contract. The BUYER may also deduct any amount from the SELLER (successful bidder) payment due as deemed necessary. Liquidated damages for the delayed/undelivered stores/goods/services/installation as mentioned above, subject to the maximum value of the Liquidated Damages being not higher than 10% of the total project cost/contract value.

In case of delay attributed solely to the negligence of the firm (service provider) in the execution of supply of goods, service, etc., penalties at the following rates shall be imposed. The delay shall be based on the agreed implementation schedule as per the service level agreement/bid document:

- (a) 1% of the total cost for delay upto 15 days;
- (b) 2% of the total cost for delay more than 15 days but less than 30 days;
- (c) 5% of the total cost for delay more than 30 days but less than 60 days;
- (d) 10% of the total cost for delay more than 60 days;

The competent authorities of the Institute reserve the right to increase the supply/installation/service etc. time period on the request of the firm or its own reasons or waive off the penalty. Maximum delay of 75 days is tolerable, beyond which the order/agreement is liable to be cancelled. The loss incurred due to non-performance of the firm/vendor will be recovered from the firm/vendor.

27. Effective Date of the Supply Order:

The work/supply/contract Order shall come into effect from the date three days later of its issuance by the NIT Sikkim. The firm has to acknowledge the same and shall remain valid until the completion of the obligations of the parties under the Order. The deliveries, supplies and performance of the services shall commence from the effective date of the Order. In case of non-receipt of acknowledgement from the Bidder, effective date of the Order will be the three day from the date of signing this Order.

[Seal and Signature of the firm]

28. Penalty for use of Undue influence:

The Seller undertakes that he has not given, offered or promised to give, directly or indirectly, any gift, consideration, reward, commission, fees, brokerage or inducement to any person in service of the Buyer or otherwise in procuring the Contracts/work orders or forbearing to do or for having done or forborne to do any act in relation to the obtaining or execution of the present Contract or any other Contract with the Institute for showing or forbearing to show favour or disfavour to any person in relation to the present Contract or any other Contract with the Institute. Any breach of the aforesaid undertaking by the Seller or any one employed by him or acting on his behalf (whether with or without the knowledge of the Seller) or the commission of any offers by the Seller or anyone employed by him or acting on his behalf shall entitle the Buyer to cancel the contract and all or any other contracts with the Seller and recover from the Seller the amount of any loss arising from such cancellation. A decision of the Buyer or his nominee to the effect that a breach of the undertaking had been committed shall be final and binding on the Seller. Giving or offering of any gift, bribe or inducement or any attempt at any such act on behalf of the Seller towards any officer/employee of the Buyer or to any other person in a position to influence any officer/employee of the Buyer for showing any favour in relation to this or any other contract, shall render the Seller to such liability/penalty as the Buyer may deem proper, including but not limited to termination of the contract, imposition of penal damages, forfeiture of the Bank Guarantee and refund of the amounts paid by the Buyer.

29. Termination of Contract:

The Buyer shall have the right to terminate this Contract in part or in full in any of the following cases:-

- (a) Contract can be cancelled/ terminated unilaterally by the buyer in case items are not received within the contracted delivery period. Extension of contracted delivery period will be at the sole discretion of the Buyer with applicability of LD (Liquidated Damages) clause mentioned above.
- (b) The Seller is declared bankrupt or becomes insolvent.
- (c) The delivery of material is delayed due to causes of Force Majeure by more than three months.
- (d) The Buyer has noticed that the Seller has utilized the services of any Indian/Foreign agent in getting this contract and paid any commission to such individual/company etc.
- (e) As per decision of the Arbitration.

30. Notice

Any notice required or permitted by the contract shall be written in the English language and may be delivered personally or may be sent by email/FAX or registered pre-paid mail/airmail, addressed to the last known address of the party to whom it is to be sent.

[Seal and Signature of the firm]

31. Transfer and Sub-letting

The Seller has no right to give, bargain, sell, assign or sublet or otherwise dispose of the Contract or any part thereof, as well as to give or to let a third party take benefit or advantage of the present Contract or any part thereof.

32. Amendments

No provision of present Contract shall be changed or modified in any way (including this provision) either in whole or in part except by an instrument in writing made after the date of this Contract and signed on behalf of both the parties and which expressly states to amend the present Contract.

33. Delivery Commercial Aspects

Prices must be quoted on F.O.R. Destination basis by road/rail/air, etc. inclusive of Packaging, Forwarding, Freight charges, Transit Insurance and any other charges as applicable. The safe and sound delivery of the goods/items etc. at the destination shall be the responsibility of the supplier. The consignee for the contract is Registrar/Store Officer of the Institute.

34. Payment Terms

It will be mandatory for the Bidders to provide bank details for e-payment. A copy of the model mandate form prescribed by RBI to be submitted by Bidders for receiving payments through ECS. 100% payment shall be made in Indian Rupees and in favor of Seller/supplier through cheque/e-payment after delivery.

35. Advance Payments: No advance payment(s) will be made.

36. Paying Authority

The Director, NIT Sikkim shall be the payment authority. The payments of bills will be made on submission of the following documents by the **seller** to the paying authority along with the bill:

- (a) Ink-signed copy of Commercial invoice/contingent bill/seller's bill in duplicate/triplicate copy.
- (b) Exemption certificate for GST, if applicable (BY BUYER).
- (c) Details for electronic payments viz. Account holder's name, Bank name, Branch name and address, Account type, Account number, IFSC code, MICR code (if these details are not incorporated in supply order/contract).
- (d) Any other document/certificate that may be provided for in the Supply Order/Contract.

(Note: From the above list, the documents that may be required depend upon the peculiarities of the procurement being undertaken).

37. Risk and Expense Clause

- (a) Should the stores or any installment thereof not be delivered within the time or times specified in the contract documents, or if defective delivery is made in respect of the stores or any installment thereof, the Buyer shall after granting the Seller 30 days to cure the breach, be at liberty, without prejudice to the right to recover liquidated damages as a remedy for breach of contract, to declare the contract as cancelled either wholly or to the extent of such default.
- (b) Should the good/stores or any installment thereof not perform in accordance with the

[Seal and Signature of the firm]

specifications/ parameters provided by the SELLER during the check proof tests to be done in the BUYER, the BUYER shall be at liberty, without prejudice to any other remedies for breach of contract, to cancel the contract wholly or to the extent of such default.

- (c) In case of a material breach that was not remedied within 30 days, the BUYER shall, having given the right of first refusal to the SELLER be at liberty to purchase, manufacture, or procure from any other source as he thinks fit, other stores of the same or similar description to successful completion of the project in all respect.
- (d) Any excess of the purchase price, cost of manufacturer, or value of any stores procured from any other supplier as the case may be, over the contract price appropriate to such default or balance shall be recoverable from the SELLER. Such recoveries shall not exceed 10% of the value of the contract.

38. Quality:

The quality of the stores delivered according to the present Contract shall correspond to the technical conditions and standards valid for the deliveries of the same stores for in Seller's country or specifications enumerated as per BID/TENDER and shall also include therein modification to the stores suggested by the Buyer. The following Specification clause will form part of the contract placed on successful Bidder:

The Seller guarantees to meet the specifications given in the bid document/tender and to incorporate the modifications to the existing design configuration to meet the specific requirement of the Buyer Services as per modifications/requirements recommended after the Evaluation Trials. All technical literature and drawings shall be amended as per the modifications by the Seller before supply to the Buyer. The Seller in consultation with the Buyer may carry out technical upgradation/alterations in the design, drawings and specifications not affecting the cost or as agreed by the seller. This will however, not in any way, adversely affect the end specifications of the goods/items. Changes in technical details, drawings, services, repair and maintenance techniques along with necessary tools as a result of upgradation/alterations will be provided to the Buyer free of cost within stipulated time, if required. This shall be binding on the Seller to comply above in the interest of the Institute.

39. Inspection Authority

The Inspection will be carried out by a Technical Committee appointed by the Institute. The mode of Inspection will be Technical Committee Inspection/or as defined by the Institute. The committee may suggest the seller with respect to above quality clause for compliance.

40. Franking Clause

The following Franking clause will form part of the contract placed on successful Bidder:-

- (a) Franking Clause in the case of Acceptance of Goods "The fact that the goods have been inspected after the delivery period and passed by the Inspecting Officer/committee will not have the effect of keeping the contract alive. The goods

[Seal and Signature of the firm]

are being passed without prejudice to the rights of the Buyer under the terms and conditions of the contract”.

- (b) Franking Clause in the case of Rejection of Goods “The fact that the goods have been inspected after the delivery period and rejected by the Inspecting Officer/committee will not bind the Buyer in any manner. The goods are being rejected without prejudice to the rights of the Buyer under the terms and conditions of the contract.”

41. Claims

The following Claims clause will form part of the contract placed on successful Bidder:-

- (a) The claims may be presented either:-
- (i) On quantity of the stores, where the quantity does not correspond to the quantity shown in the Packing List/Insufficiency in packing.
 - (ii) On quality of the stores, where quality does not correspond to the specifications/quality mentioned in the contract.
- (b) The description and quantity of the stores are to be furnished to the Seller along with concrete reasons for making the claims. Copies of all the justifying documents shall be enclosed to the presented claim. The Seller will settle the claims within 30 days from the date of the receipt of the claim at the Seller’s office, subject to acceptance of the claim by the Seller. In case no response is received during this period the claim will be deemed to have been accepted.
- (c) The Seller shall collect the defective or rejected goods from the location nominated by the Buyer and deliver the repaired or replaced goods at the same location under Seller’s arrangement.
- (d) Claims may also be settled by reduction of cost of goods under claim from bonds submitted by the Seller or payment of claim amount by Seller through demand draft drawn on an Indian Bank in favor of the Director/Registrar of the Institute.
- (e) The quality claims will be raised solely by the Buyer and without any certification/countersignature by the Seller’s representative stationed in India.

Note Carefully: The Bidder is required to read and examine all the terms and conditions, specifications and instructions given in the TENDER/BID document with full understanding of its implications. Failure to furnish any information required for submission of a bid or bids not substantially responsive in every respect may result in outright rejection. The Bidder is required to give and undertaking of understanding and acceptance of all the terms and conditions mentioned in the Bid document. The sole responsibility in all respect lies with the bidder and NIT Sikkim shall not be held responsible in any respect in this regard.

**Registrar
NIT Sikkim**

[Seal and Signature of the firm]

The detail technical specification for Double Decker Cot

| Parts | Name | Specifications |
|-------|-------------------------------------|---|
| 1 | Bed Assembly | The complete double decker cot will be assembled as per the drawing and directions of the Institute Authority/In-charge. Head board & tail board (As per drawing Part 1 & Part 2) are made of square pipe 50 mm × 50 mm, rectangular pipe 25 mm × 50 mm and 25 mm round pipe as mentioned in the drawing. The bed frame 1985 mm x 905 mm made of 50 mm x 25 mm rectangular pipe and 25mm square pipe as per the drawing (part 3 & 4). The detail of each parts are mentioned in the drawing. Bed top shall be of waterproof ISI mark plywood (make Shivam/Konark/Century/Everest) of 12 mm thickness fitted with counter sunk screw (9Nos.) and painted dark brown with oil paint. The plywood must be fitted inside the bed frame. |
| 2 | Design & Dimension | As mentioned in the drawing. Tolerance on dimension (i) Linear dimension ± 3.0 mm (ii) Tolerance of Material may be referred to relevant materials IS specification. |
| 3 | Ladder | Square pipe 25 mm X 1.5 mm thickness shall be fixed with frame by MIG Welding. |
| 4 | Joints | All Joints have to be made by appropriate MIG welding unless otherwise mentioned. |
| 5 | Welding Type | MIG welding |
| 6 | Nut & Bolt | Hexagonal headed self-washer M12X 70 mm nut bolt set or similar kind fasteners must be used for fixing part 3 & 4 with Part 1 & 2 as shown in the drawing. |
| 7 | Leg & Shoes | PVC shoe with nominal height of minimum 35mm. |
| 8 | Side support guard in top bed frame | 25.4 mm round pipe as per the drawing. The suitable MS clamps have also to be provided to fix the bed with walls. |
| 9 | Finish | Buffing finish and joints are also to be properly finished. |
| 10 | Material | All parts of the bed must be made of Stainless steel grade AISI 202 SS (Make JINDAL or better) and 16 Gauge (>1.5 mm) or as per the drawing. |
| 11. | Weight | Minimum weight of the SS frame (without ply board) is approx 65Kg |

[Seal and Signature of the firm]

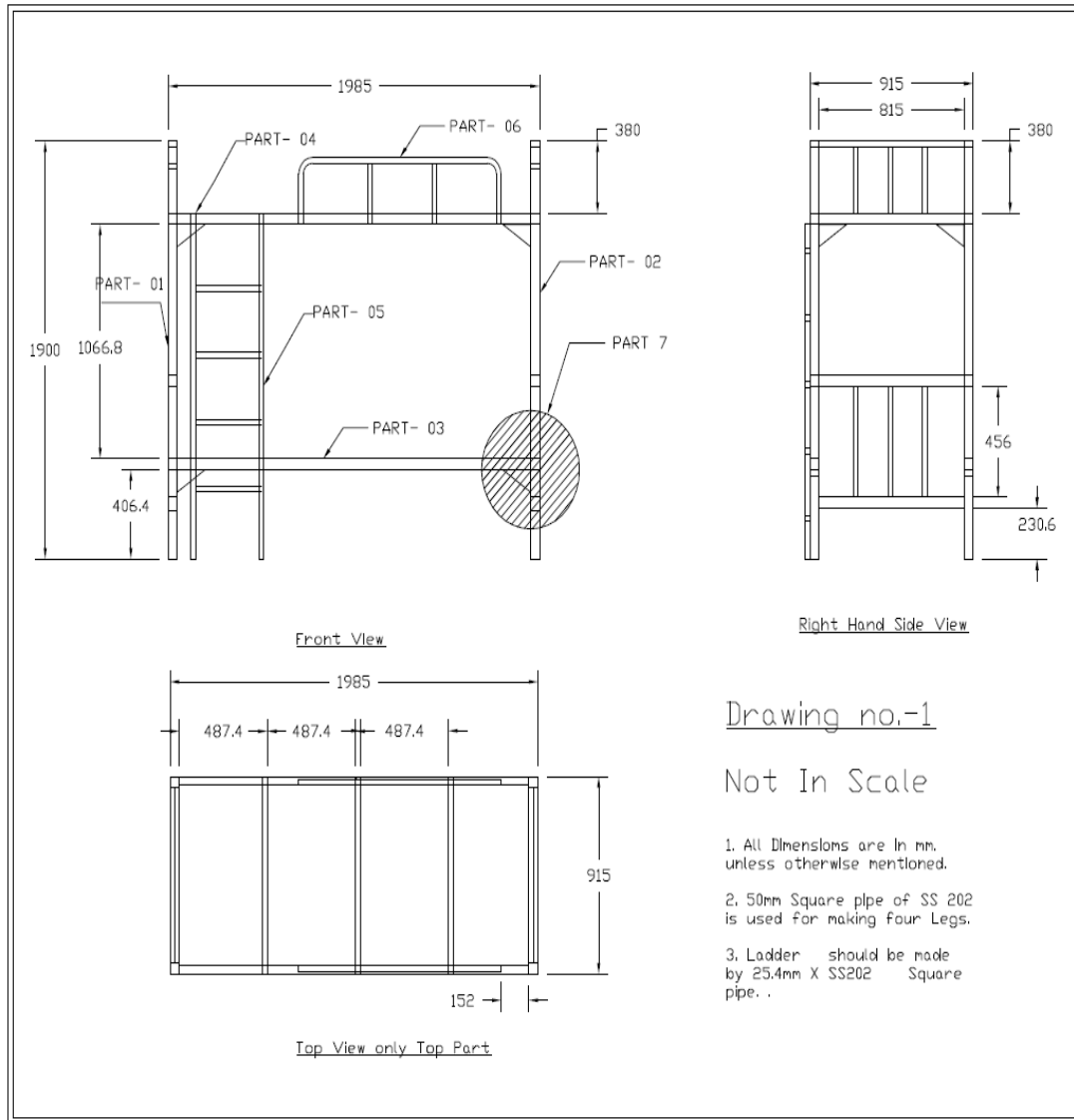

Drawing no.-1

Not In Scale

1. All Dimensions are in mm, unless otherwise mentioned.
2. 50mm Square pipe of SS 202 is used for making four Legs.
3. Ladder should be made by 25.4mm X SS202 Square pipe. .

[Seal and Signature of the firm]

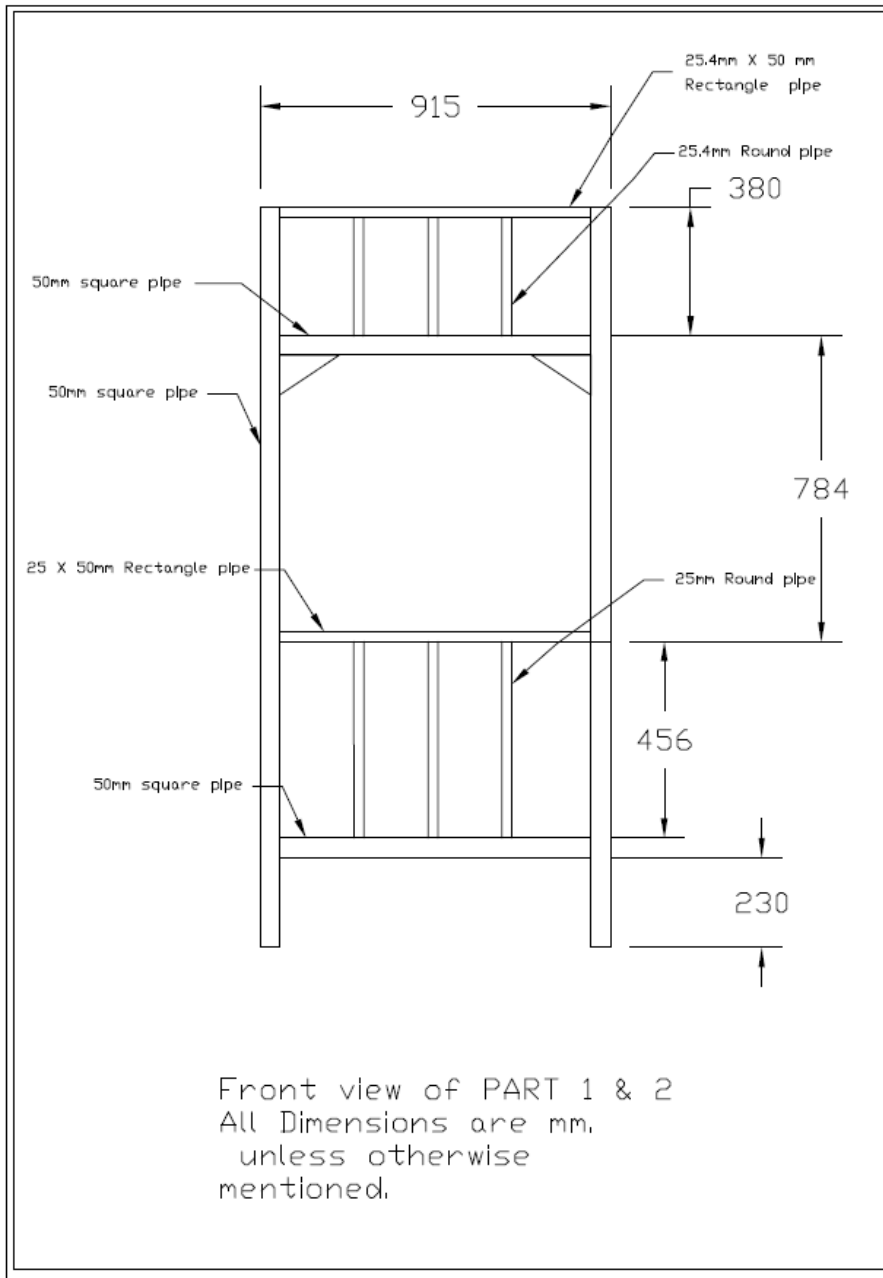

[Seal and Signature of the firm]

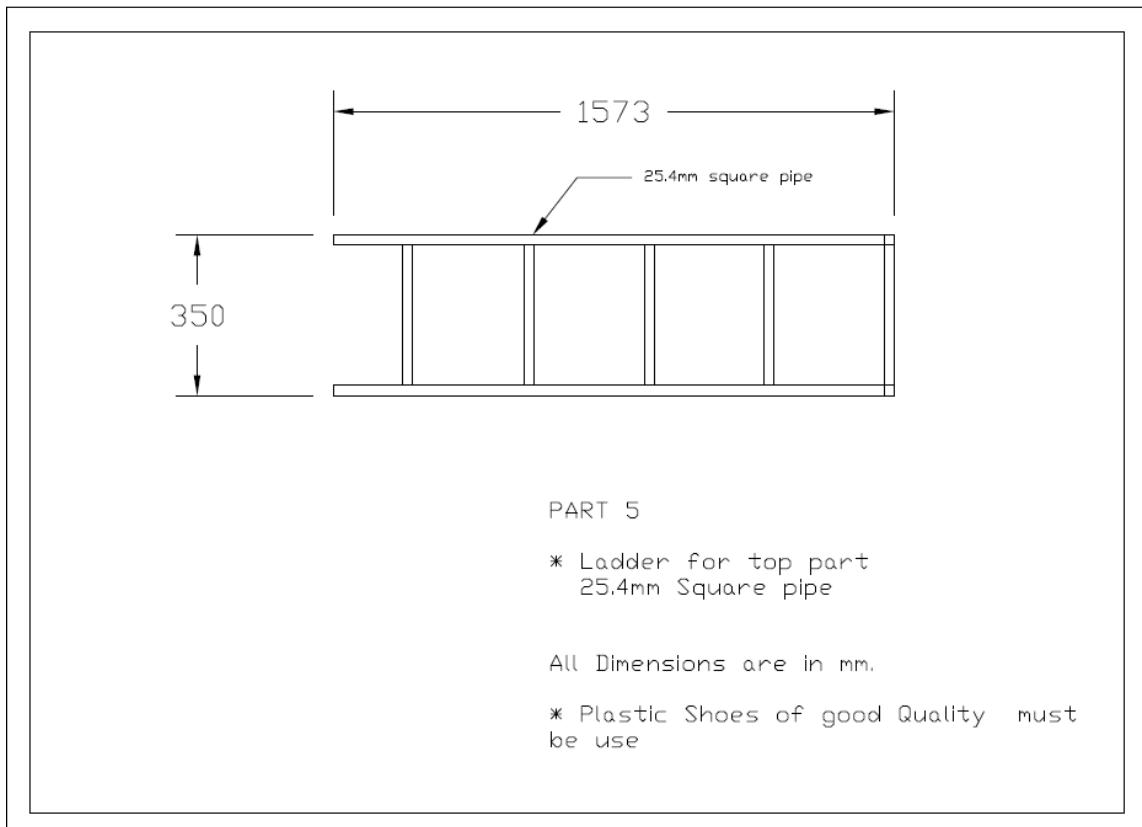
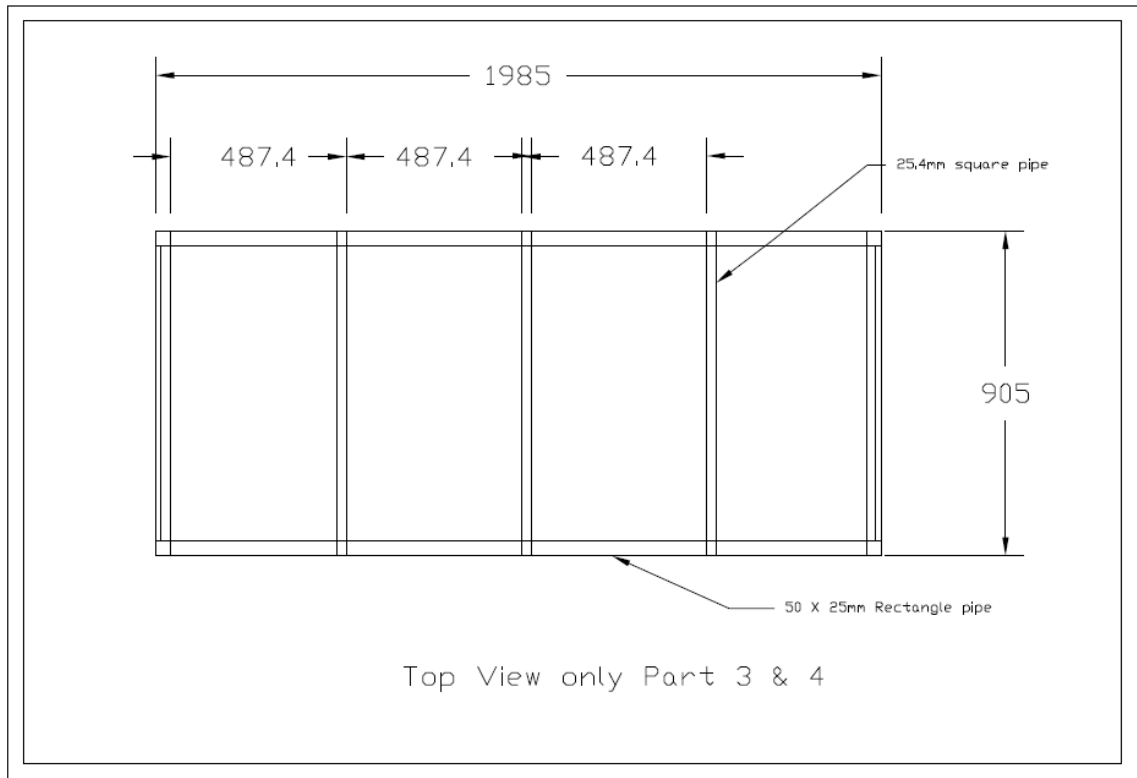

[Seal and Signature of the firm]

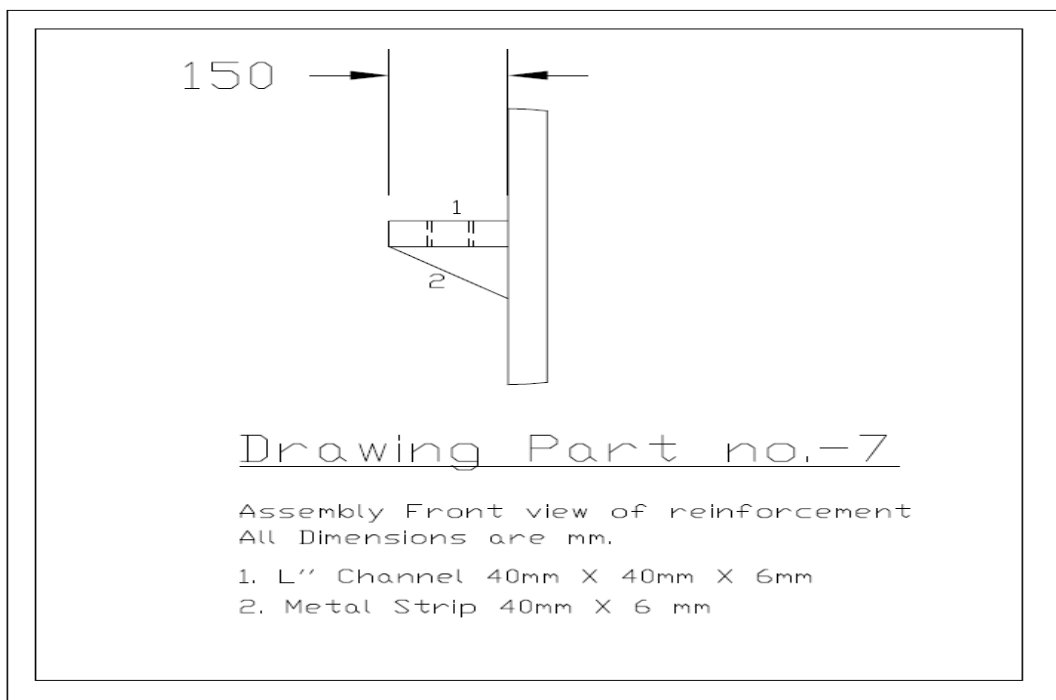
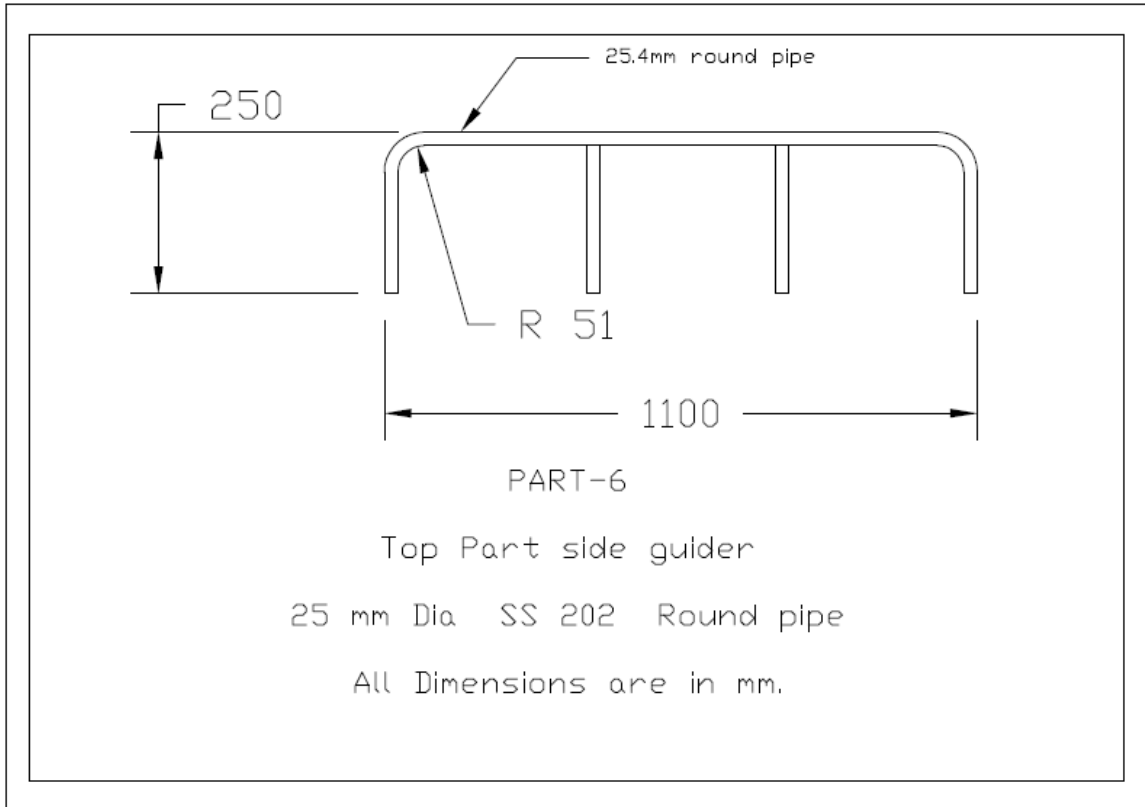

[Seal and Signature of the firm]

Annexure-A**PART A: Format for submission of Technical Bid**

Format for Profile of the bidder

| Sl No. | Particulars | Fill-in Details | Ref No/ remarks if any |
|--------|--|-----------------|------------------------------|
| 01 | Name and address of the Firm / Agency | | |
| 02 | Whether the firm is Proprietary / Partnership Firm / Private Ltd. / Public Ltd. / Others. | | |
| 03 | Name of Proprietor / Partner of the firm / Agency | | |
| 04 | Name & contact detail of Authorized representative: (Designation, Address, Mobile no, E-mail ID) | | |
| 05 | Month and Year of Establishment of Firm* | | |
| 06 | Number of years of experience in this field* | | |
| 09 | Registration Number of the Firm* | | |
| 10 | Valid GSTIN Number | | |
| 11 | PAN number of the firm or Proprietor* | | |
| 12 | Trade License related to Metal/Steel furniture and fabrication business (should be valid for financial year 2018-19) | | |
| 13 | Workshop Facility Address | | |
| 14 | Number of Skilled fabricators/welders employed. | | |
| 15 | Other relevant documents as mentioned under "submission of tender document" & General Terms & Condition | | |

*All fields are mandatory to fill with the copy of duly signed and the above points together constitute eligibility criteria.

Detail of Demand Draft submitted for EMD:

| Sl. No. | Demand Draft no | Date | Amount |
|---------|-----------------|------|--------|
| | | | |

[Seal and Signature of the firm]

Annexure-B**PART B: Financial Bid**

(To be sealed in a separate envelope duly signed)

| Name of items | Unit Price (₹) | GST (@ %) | Qty | Total Unit Price (₹) | Grand Total F.O.R NIT Sikkim (₹) inclusive all taxes # |
|-----------------------------------|----------------|-----------|-----|----------------------|--|
| Stainless Steel Double Decker Bed | | | 100 | | |

(Total Amount in words for 100 Nos beds

Total unit quoted price should be inclusive all charges (taxes, transportation charges).
NO extra charges will be paid.

Bank Account Details for Direct Payment**To be submitted by bidder**

| Sl. No. | Particulars | |
|---------|---|--|
| 1 | Firm (Beneficiary) Name | |
| 2 | Please enclose a cancelled cheque | |
| 3 | Complete Bank Account No. of the Firm [beneficiary] | |
| 4 | Bank Name & Address | |
| | IFSC Code no | |
| 6 | Mobile no & Email ID for information | |

We undertake that all information provided above is correct and NIT Sikkim will not be responsible in case of any error on the part of firm.

[Seal and Signature of the firm]

Annexure-C

Undertaking (On the letter head of the bidder)

To
The Director
NIT Sikkim

Sub.: Undertaking for *Tender No: NITS/S&P/FURNITURE/18-19/75* *Date: June 15th, 2018*

Dear Sir,

This is to undertake that I / We, owner(s) of M/s, of (name of city) have read all the terms and conditions, specifications etc. of the above mentioned Tender document and I / We fully understood all of them and I/We are fully aware of its implications. We undertake that if I / We were given the Purchase Order, I / We will abide by all the terms and conditions of the Tender and provide all the items to the satisfaction of the institute authorities.

I further undertake that the fabrication work shall be carried out at NIT Sikkim campus and commenced within 7 days of award of contract.

Signed by

(Name)

Authorized Signatory of M/s

Official Stamp

Date:

Place:

[Seal and Signature of the firm]