



NATIONAL INSTITUTE OF TECHNOLOGY SIKKIM

Ravangla Campus

Barfung Block, Ravangla Sub Division, South Sikkim-737139

Tender No:56 /Academic/NITS/DICSA/FURNITURE/17-18/Furniture

Date: May 29th , 2018

Tender Notice

National Institute of Technology Sikkim invites tenders in sealed envelope for fabrication & supply of student cots as per specification given in this tender to be supplied at NIT Sikkim, Ravangla, South Sikkim 737139. The tender documents can be downloaded free of cost from the website www.nitsikkim.ac.in or obtained from the office .

Schedule of Requirements

Name of Item	Quantity	Delivery period
Stainless Steel Double Decker Cot	100	30 Days

Details	Information
Tender Floating Date	May 29 th 2018
Tender Closing Date	June 12 th , 2018 (1:00 pm)
Tender Opening Date	June 12 th , 2018 (03:00 pm)
EMD Fees type	Rs 50,000/- (Rupees Fifty Thousand Only) By Demand Drafts in favour of “The Director, NIT SIKKIM” payable at State Bank of India, Ravangla Branch (IFSC SBIN0007218).
Address for communication	Registrar National Institute of Technology Sikkim Barfung Block, Ravangla Sub-division South Sikkim, Sikkim PIN 737 139, INDIA
For any Clarification	<i>e-mail:- purchaseoffice@nitsikkim.ac.in</i>
Website	<i>www.nitsikkim.ac.in</i>

Registrar

General Terms and Conditions

1. Experienced fabricators, manufacturers, suppliers or dealers of stainless steel furniture may bid for the quoted item. **The trade license submitted by the bidder must clearly mention the trade in which the bidder operates.**
2. All bidding documents and rate quotations must be in English on letter head of bidding firm and duly stamped by the authorized signatory along with a forwarding letter. One signed copy of the tender document, with bidding firm seal, agreeing to the terms & conditions and declaration must also form part of the documents.
3. **Components must be ISI certified and the components used in the making of the item must be clearly mentioned. A declaration of the brand of components to be used in the fabrication and its certification must be enclosed in the bid documents.**
4. Bidder should have valid **GST registration** for the financial year 2018-19. Only invoices with serial numbers and printed with **GSTIN** number shall be accepted.
5. **Earnest Money Deposit (EMD)** has to be submitted in form of Demand Draft (DD) in favour of “*Director, NIT Sikkim*”. **No interest shall be paid on the submitted EMD.** Offer without EMD and tender fee will be rejected summarily except in case of exempted bidders holding valid MSME/NSIC license exempting such bidders from furnishing of EMD. **Submitted EMD** will be returned to unsuccessful bidders.
6. Bid or order may be cancelled or delivered furniture may be not be accepted fully or partially at any time if it is found that stainless steel double decker cot differs or deviates from NIT Sikkim’s mentioned and accepted specification in the bid. Any action under this clause shall make the EMD/security deposit liable to be forfeited.
7. Packing, forwarding, insurance (if any), transportation charges should be inclusive in the price. For any damage/loss during transit, supplier will be solely responsible and damaged/lost furniture must be replaced by supplier at their own cost.
8. **Validity:** Bids shall remain valid for 180 days from date of the Tender closing Date.
9. **Opening of Bid:** The bids will be securitized by the constituted committee based on requirement suiting to the need of the Institute. Decision of the Institute committee will be final and binding. No query shall be raised on any act or omission of the committee. Any defect in the constitution/quorum/functioning of the committee not affecting the merits of the bid shall not invalidate any decision of the committee.

10. All the terms and conditions mentioned herein must be strictly adhered to by all the vendors. **Conditional tenders shall not be accepted on any ground and shall be rejected straightway.** Conditions mentioned in the tender bids submitted by vendors will not be binding on NIT Sikkim
11. **F.O.R. NIT Sikkim:** The quoted price must include the transportation up to NIT Sikkim Ravangla campus and successful assembling if any of cots. Any other separate charge (s) will not be paid to vendor. Vendor will be solely responsible for required documents for delivering goods to NIT Sikkim located at Ravangla.
12. **Security deposit:** The successful bidder will have to deposit 2% of the order value in form of PBG or may opt to convert the EMD into security deposit for a period of 6 months.
13. **Delivery Period:** Delivery period for the cots shall be **30 days from date of** issue of Purchase order. The institute reserves the right to extend the delivery time on the request with valid reason. Liquidity damage will be levied in case of failure to abide by the delivery period.
14. **Responsibility of ensuring quality** with specification lies to the supplier. **The supplying firm must ensure approval of the sample cot by the committee before delivery.** Deviation of technical specification from the approved sample may lead to rejection of delivery or cancellation of order along with forfeiture of EMD. However, in case of minor change in design may be asked by the institute based on the sample and successful bidder is bound to comply with the same.
15. **Payment condition:** 100% payment shall be made in Indian Rupees and in favor of bidder through cheque / RTGS after delivery.
16. **Liquidity damage:** In case of failure in supply and installation within the specified period or parts of material, liquidity damage shall be charged at the rate of 0.25% of PO value per week.
17. If supplier fails to deliver the cots within the delivery period, NIT Sikkim may cancel full order or parts of the order and EMD value may not be returned to the bidder. NIT Sikkim also reserves the right to place the order for the cots to other bidder or supplier in case of failure of the successful bidder. The EMD shall be forfeited in case the supplier withdraws his tender offer during the validity period of the bid.
18. **Warranty/Guarantee support:** six months onsite comprehensive warranty from the date of successful delivery should be provided by the bidder. Certificate mentioning acceptance of this clause should be enclosed with the bid.

19. **Acceptance of Tender:** The Authority of NIT Sikkim does not bind itself to accept the lowest priced bid and reserves the right to reject any or the entire tender bids received without assigning any reason thereof.
20. **Extra Features:** If the bidder provides any other extra features on the material/specification which are not mentioned in the tender product specifications, then that shall be highlighted in clear terms, with documentary evidence/literature.
21. Bidder may choose authorized representative with proper authorization letter for attending tender document opening.
22. A bid submitted with false information will not only be rejected but also the bidder will be debarred from participation in future tendering process of NIT Sikkim.
23. In case of any dispute, the decision of the Institute Authority shall be final and binding on the bidders.
24. Credential of supply of similar fabricated furniture to central Govt. / autonomous educational Institute may be attached.
25. The authority is not bound to accept the lowest quoted rate if the bidder does not fulfill all requisites as considered necessary **in any case the quality of product will not be compromised.**
26. **Any defective material pointed out by authorized representative of the Institution the same shall be taken back by the suppliers for replacement at their own cost.**
27. **The bidder must enclose a valid trade license, GST registration certificate, PAN, or any other certificate evidencing quality, or statutory compliance along with the bid documents duly certified to be true copies.**
28. **Jurisdiction:** The Courts of Sikkim alone will have the jurisdiction to try and any matter dispute or reference between the parties arising out of this tender. The order shall be interpreted in accordance with the laws of the Union of India.

Other Terms & Conditions

1. Arithmetical errors will be rectified on the following basis. If there is discrepancy between the unit price and the total price, the total price shall be corrected. If there is a discrepancy between words and figures, the amount in words will prevail. If the supplier does not accept the correction of errors, its bid will be rejected and its bid security may be forfeited.
2. NIT Sikkim may waive any minor informality or non-conformity or irregularity in a bid, which does not constitute a material deviation, provided such a waiver, does not prejudice or affect the relative ranking of any bidder.
3. The furniture to be supplied under this contract shall conform to the standards mentioned in the technical specifications. And when no applicable standard is mentioned, to the authoritative standard appropriate to the goods' country of origin and such standards shall be the latest issued by the concerned institution / Organization.
4. Delivery of the Goods shall be made by the Supplier in accordance with the terms & condition specified in Purchase Order (PO) by NIT Sikkim in the Notification of Award.
5. Any subcontract of the placed order will not be entertained and order may be cancelled in summary.
6. "Force Majeure" means an event beyond the control of the supplier and not involving the supplier's fault or negligence and not foreseeable. Such events may include, but are not limited to, acts of the purchaser either in its sovereign or contractual capacity, wars or revolutions, fires, floods, epidemics, quarantine restrictions and freight embargoes. Force Majeure situation arises, the Supplier shall promptly notify Institute in writing of such conditions and the cause thereof for consideration.
7. NIT Sikkim reserves right to award the order to one or more bidder.
8. **Supply of the stainless steel cot shall be to the satisfaction in all terms of NIT Sikkim, else no payment will be made.** The decision of competent authority of NIT Sikkim shall be final and binding on firms / Suppliers.
9. NIT Sikkim reserves the right to modify in exceptional case any of the stipulated terms and conditions on merit / genuine and justifying grounds if it is in the larger interest of the Institute. The final acceptance of the tenders rests entirely with the NIT Sikkim who does not bind himself to accept the lowest tender. The selection will be made purely on the basis of committee's recommendation, genuineness of the

firm and based on the technical specification of various products as per printed catalogues & also on the basis of experience, performance, promptness of delivery and requirement of the institute.

10. NIT Sikkim official may visit the work place of successful bidder and can review the progress of the work and can instruct the quality.
11. NIT may ask for proof of bills or other relevant document for purchase of the material as per desired standard specification i.e. Ply, laminated sheet, square pipes, angles with brands during final payment.

Registrar
National Institute of Technology Sikkim

The detail technical specification for Double Decker Cot

Parts	Name	Specifications
1	Bed Assembly	The complete double decker cot will be assembled as per the drawing and directions of the Institute Authority/In-charge. Head board & tail board (As per drawing Part 1 & Part 2) are made of square pipe 50 mm × 50 mm, rectangular pipe 25 mm × 50 mm and 25 mm round pipe as mentioned in the drawing. The bed frame 1985 mm x 905 mm made of 50 mm x 25 mm rectangular pipe and 25mm square pipe as per the drawing (part 3 & 4). The detail of each parts are mentioned in the drawing. Bed top shall be of waterproof ISI mark plywood of 12 mm thickness fitted with counter sunk screw (9Nos.) and painted dark brown with oil paint. The plywood must be fitted inside the bed frame.
2	Design & Dimension	As mentioned in the drawing. Tolerance on dimension (i) Linear dimension ± 3.0 mm (ii) Tolerance of Material may be referred to relevant materials IS specification.
3	Ladder	Square pipe 25 mm X 1.5 mm thickness shall be fixed with frame by MIG Welding.
4	Joints	All Joints have to be made by appropriate MIG welding unless otherwise mentioned.
5	Welding Type	MIG welding
6	Nut & Bolt	Hexagonal headed self-washer M12X 70 mm nut bolt set or similar kind fasteners must be used for fixing part 3 & 4 with Part 1 & 2 as shown in the drawing.
7	Leg & Shoes	PVC shoe with nominal height of minimum 35mm.
8	Side support guard in top bed frame	25.4 mm round pipe as per the drawing. The suitable MS clamps have also to be provided to fix the bed with walls.
9	Finish	Buffing finish and joints are also to be properly finished.
10	Material	All parts of the bed must be made of Stainless steel grade AISI 202 SS and 16 Gauge (>1.5 mm) or as per the drawing.

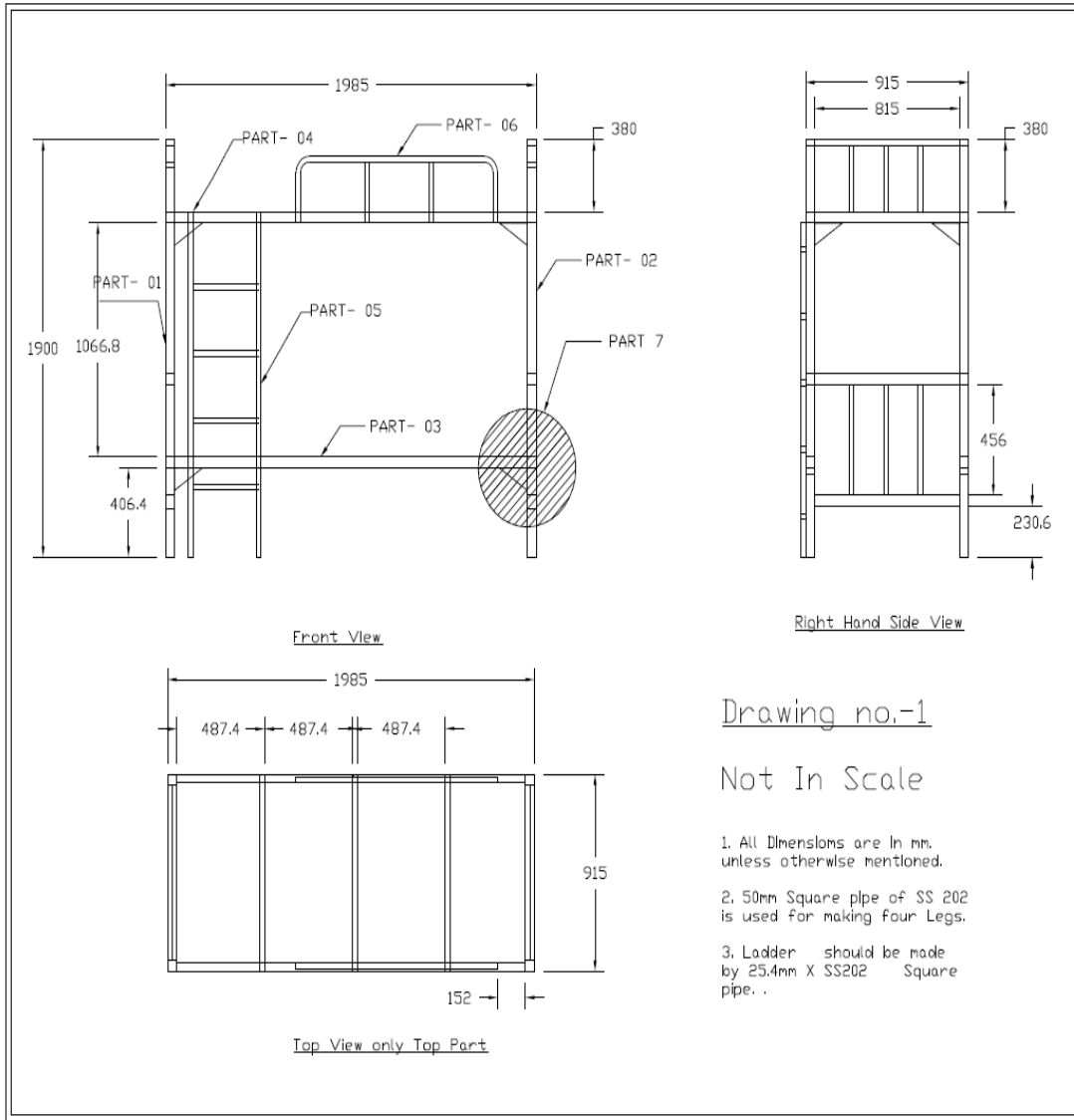

Drawing no.-1

Not In Scale

1. All Dimensions are In mm. unless otherwise mentioned.
2. 50mm Square pipe of SS 202 is used for making four Legs.
3. Ladder should be made by 25.4mm X SS202 Square pipe. .

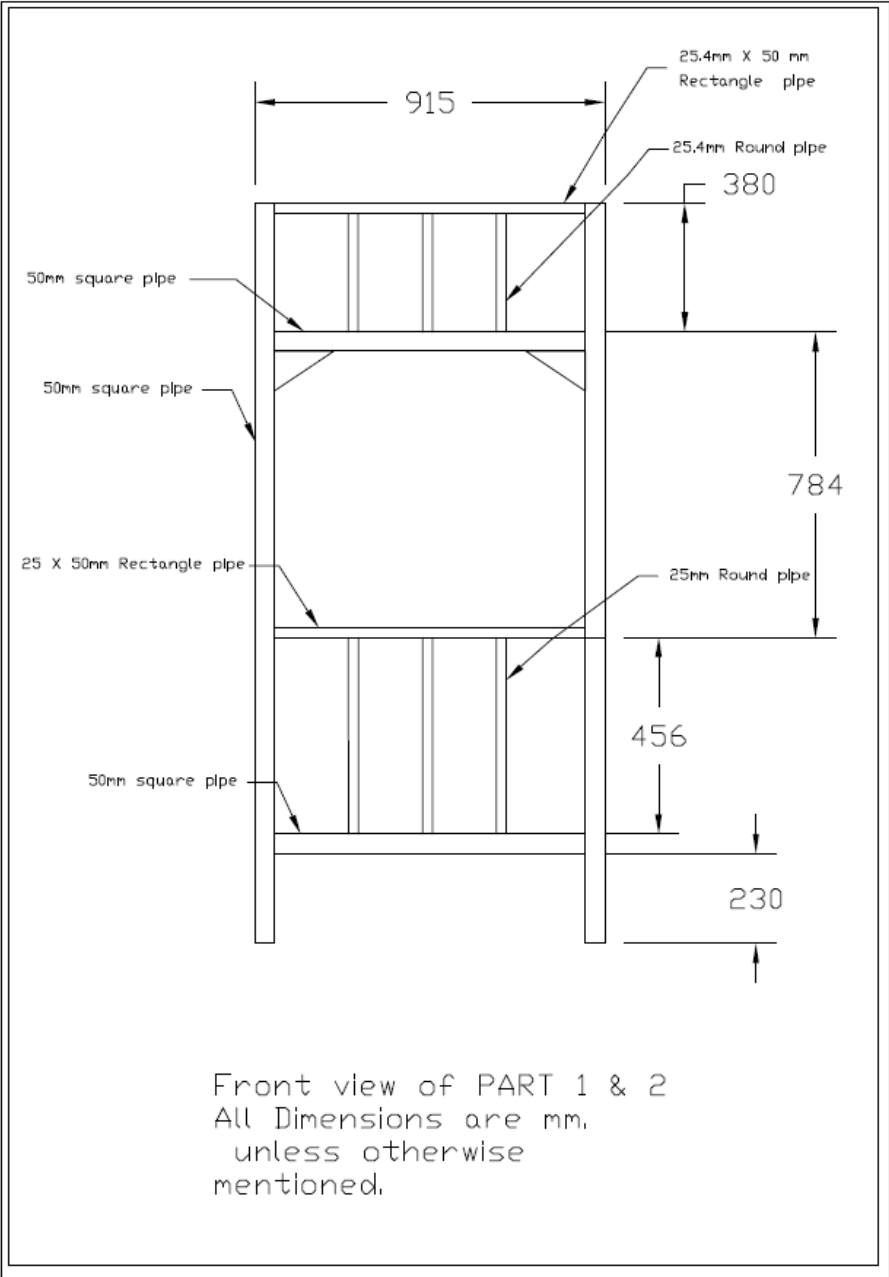

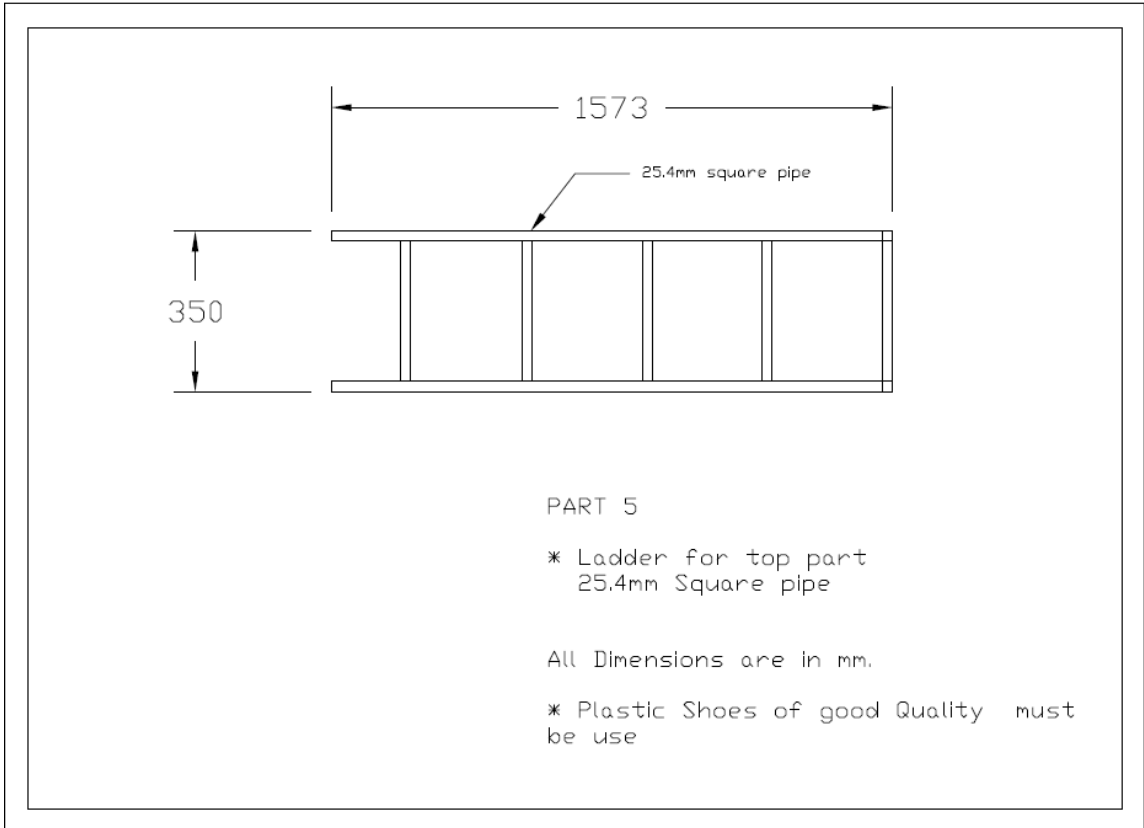
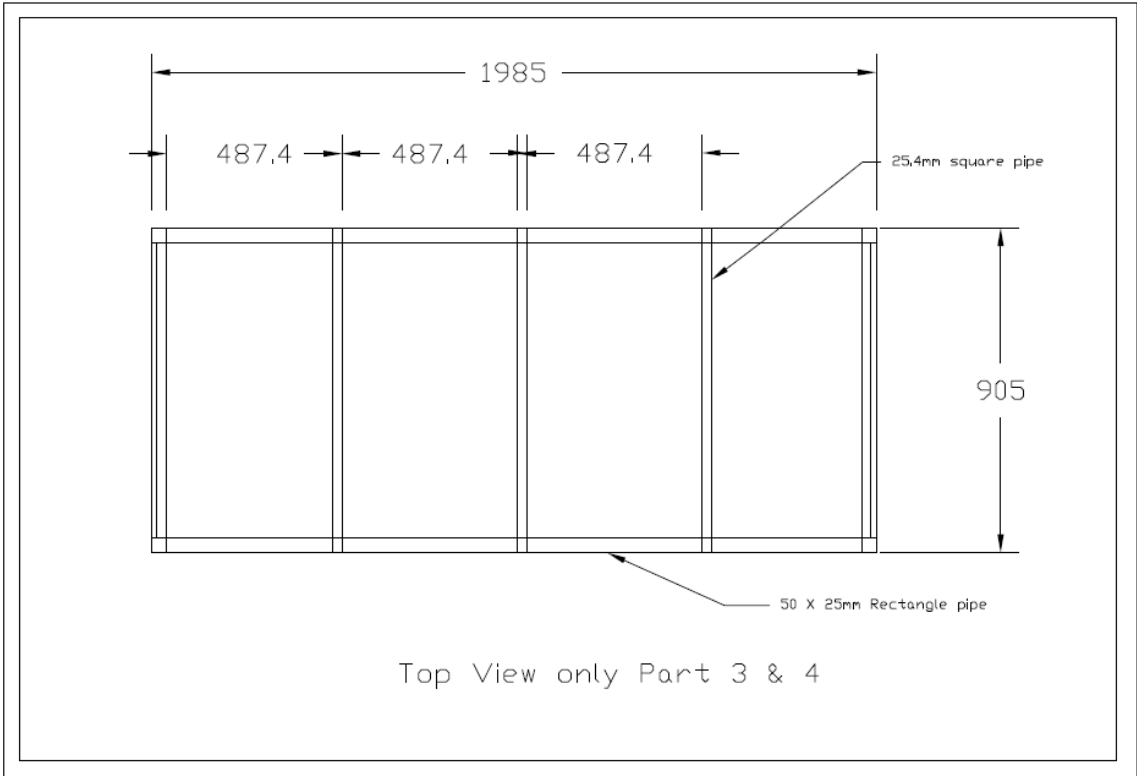

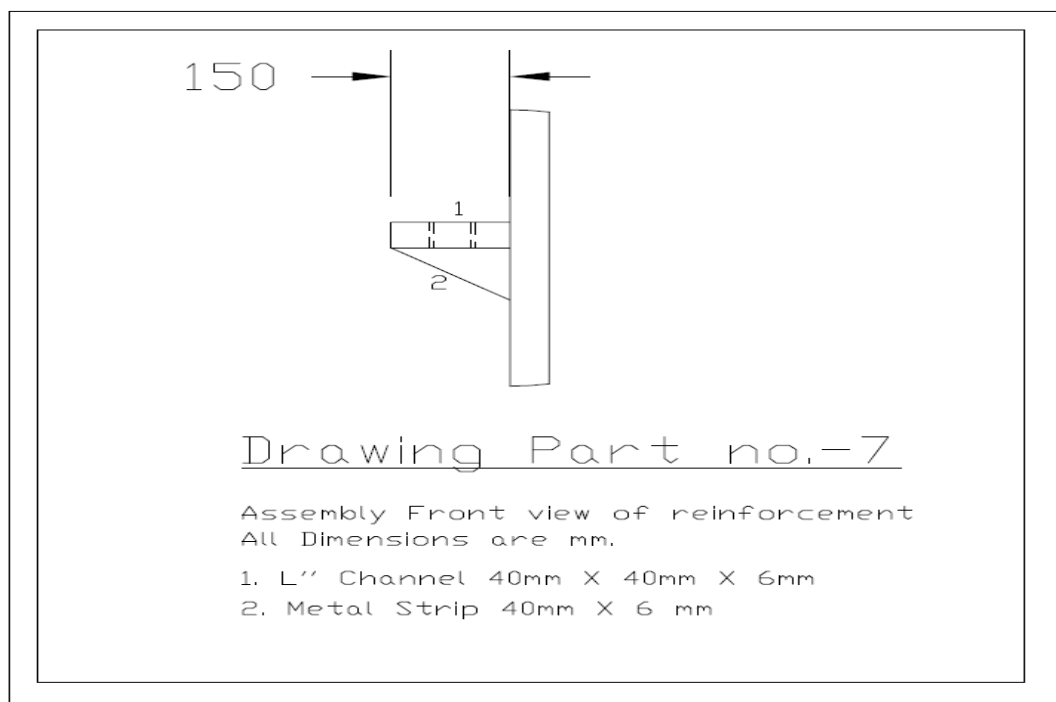
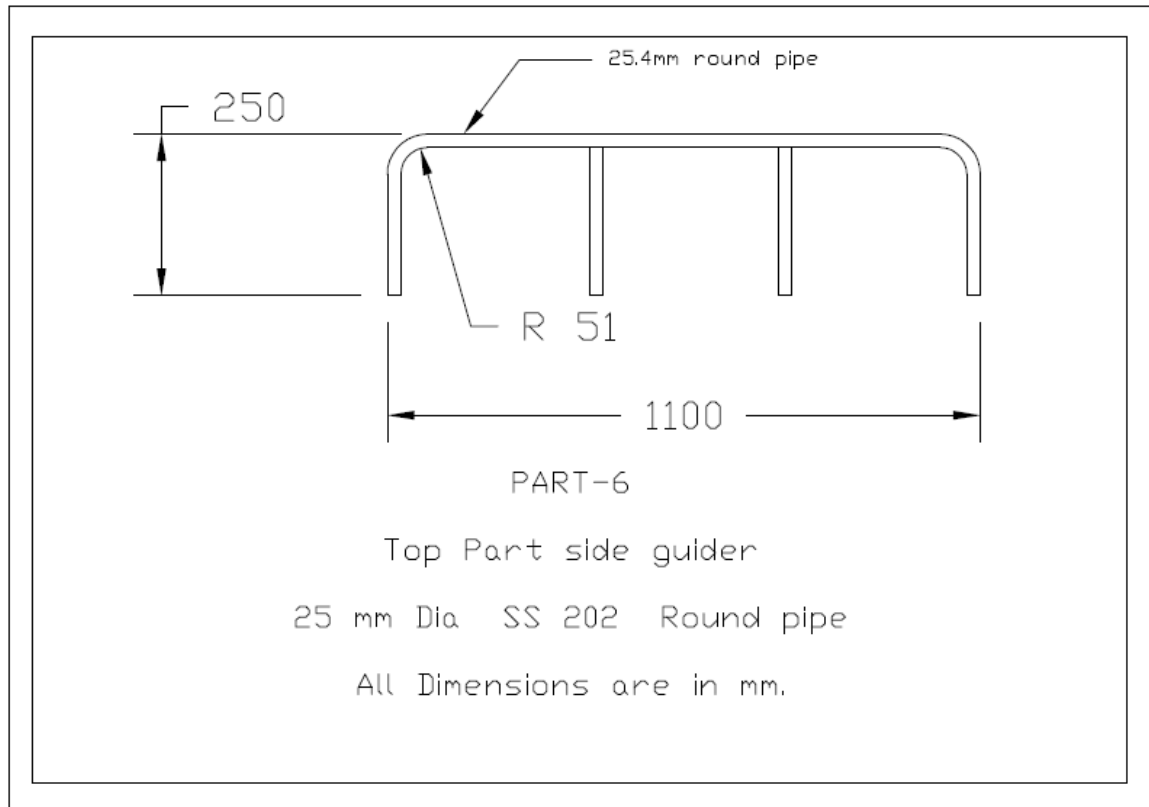

PART A: Format for submission of Technical Bid**Format for Profile of the bidder**

Sl No.	Particulars	Fill-in	Reference No/ remarks if any
01	Name and address of the Firm / Agency		
02	Whether the firm is Proprietary / Partnership Firm / Private Ltd. / Public Ltd. / Others.		
03	Name of Proprietor / Partner of the firm / Agency		
04	Name & contact detail of Authorized representative: (Designation, Address, Mobile no, E-mail ID)		
05	Month and Year of Establishment of Firm*		
06	Number of years of experience in this field*		
09	Registration Number of the Firm*		
10	Valid GSTIN Number		
11	PAN number of the firm or Proprietor*		
12	Trade License related to steel furniture and fabrication business (should be valid for financial year 2018-19)		
13	Whether Bidder has its own workshop facility and if so its location and detail		
14	Other relevant documents as mentioned under “submission of tender document” & General Terms & Condition		

***All fields are mandatory to fill with the copy of duly signed.**

Detail of Demand Draft submitted for EMD and tender fees (if any):

Sl. No.	Demand Draft no	Date	Amount

PART B: Financial Bid

(To be sealed in a separate envelope duly signed)

Name of items	Unit Price (₹)	GST (@ %)	Qty	Total Unit Price (₹)	Grand Total F.O.R NIT Sikkim (₹) inclusive all taxes #
Stainless Steel Double Decker Bed			100		

(Total Amount in words for 100 Nos beds
.....)

Total unit quoted price should be inclusive all charges (taxes, transportation charges). NO extra charges will be paid.

Bank Account Details for Direct Payment

To be submitted by bidder

Sl. No.	Particulars	
1	Firm (Beneficiary) Name	
2	Please enclose a cancelled cheque	
3	Complete Bank Account No. of the Firm [beneficiary]	
4	Bank Name & Address	
	IFSC Code no	
6	Mobile no & Email ID for information	

We undertake that all information provided above is correct and NIT Sikkim will not be responsible in case of any error on the part of firm.

[Seal and Signature of the firm]

Undertaking (On the letter head of the bidder)

To
The Director
NIT Sikkim

Sub.: Undertaking for *Tender*

No:56/Academic/NITS/DICSA/FURNITURE/17-18/Cot Date: May 20, 2018

Dear Sir,

This is to undertake that I / We, owner(s) of M/s, of (name of city) have read all the terms and conditions, specifications etc. of the above mentioned Tender document and I / We fully understood all of them and I/We are fully aware of its implications. We undertake that if I / We were given the Purchase Order, I / We will abide by all the terms and conditions of the Tender and supply all the items to the satisfaction of the institute authorities.

Signed by

(Name)

Authorized Signatory of M/s

Official Stamp

Date:

Place: